

Thomas Frederiksen, Henrik Bengtsson, and Karsten Nielsen
Bang & Olufsen PowerHouse a/s
Struer, Denmark

**Presented at
the 109th Convention
2000 September 22-25
Los Angeles, California, USA**



AES

This preprint has been reproduced from the author's advance manuscript, without editing, corrections or consideration by the Review Board. The AES takes no responsibility for the contents.

Additional preprints may be obtained by sending request and remittance to the Audio Engineering Society, 60 East 42nd St., New York, New York 10165-2520, USA.

All rights reserved. Reproduction of this preprint, or any portion thereof, is not permitted without direct permission from the Journal of the Audio Engineering Society.

AN AUDIO ENGINEERING SOCIETY PREPRINT

A novel Audio Power Amplifier Topology
with
High Efficiency and State-of-the-art performance

Thomas Frederiksen, M.Sc.E.E

E-mail: tcf@bang-olufsen.dk

Henrik Bengtsson, B.Sc.E.E (Hons)

E-mail: hbe@bang-olufsen.dk

Karsten Nielsen, Ph.D

E-mail: kst@bang-olufsen.dk

Bang & Olufsen PowerHouse a/s , Denmark

Abstract

A novel high efficiency power amplifier topology for audio reproduction is presented. The topology breaks previous performance barriers in switching technology, by combining an effective error correction method, Multivariable Enhanced Cascade Control (MECC), with a new integrated modulator topology - Controlled Oscillation Modulation (COM). This topological combination proves to be very elegant. Extensive measurements are given on 250W, 500W and 1000W case implementations of the MECC/COM topology, showing e.g. 0.0005% (-106dB) true THD combined with state-of-the-art in power and volume efficiency.

1. Introduction

Well respected audio guru Ben Duncan has stated in his book "High Performance Audio Power Amplifiers" just three years ago in 1997:

" It has been said since 1960 that once the potential shortcomings of class D have been overcome to everyone's satisfaction, class D amplification will be all there is for anything over a 100 watts or so. But it hasn't happened yet.... While simple on paper, the calibre of engineering design needed to produce a class D amplifier that doesn't radiate EMI and is measurably and audibly on a par with equivalent analog amplifiers is truly formidable ... "

Why?

Compared to linear power amplifier designs, the classical analog and digital class D or *Pulse Modulation Amplifier (PMA)* systems present numerous challenges to the designer. Just to mention a few challenges:

- The complex switching power conversion stage is difficult to model in detail and generates a significant amount of switching noise disturbing the feedback error correction system.
- The reconstruction filter further complicates the implementation of effective error correction by

implementing a higher order system transfer function.

- Feedback in the digital modulation based systems is not possible hence complicating this alternative approach.
- Significant EMI considerations are necessary in amplifier design and system implementation.

Some of the problematic issues have been reported in earlier work by Attwood and Nielsen [2], [8], [15]. Generally, the list of required competencies to design high performance power amplifier systems based on switching technology is long and moreover completely different from the competencies needed to design linear power amps. Mr. Duncan's statement given just 3 - 4 years ago and basically concludes 40 years of work on this challenging topic.

2. The MECC based PMA system

However, much has happened over the last few years

[4] -

[21]. The research activities in the field have been dramatically intensified. In an earlier paper (Paper 4839 / AES105 in San Francisco), a novel error correction topology - *Multivariable Enhanced Cascade Control (MECC)* - was proposed by one of the authors as a new contribution to the field. The topology was devised by detailed considerations of the specific design problems in audio power amplifier systems

based on switching power conversion. The MECC topology was shown to overcome the constraints of previously applied feedback control methods, and realize these objectives by remarkably simple means. MECC was verified by a first generation prototype indicating a clean break with the limitations in previous designs. Research has continued on MECC including studies on suitable modulator implementation methods and this paper proposes a novel modulator topology called the *Controlled Oscillation Modulator (COM)*.

Any *Pulse Modulation Amplifier (PMA)* power amplifier system using switching power conversion can be decomposed into three fundamental blocks: (1) the pulse modulator (analog or digital), (2) the switching power conversion stage with a passive demodulation filter and (3) the control block. A general system block diagram is shown in Fig. 1. The pulse modulation may be either analog (i.e. analog PMA) or digital (i.e. digital PMA). Independent on the use of analog or digital pulse modulation, the pulse modulator output, power stage output and filter output are inherently *analog* signals, and thus sensitive to jitter, pulse amplitude distortion or any form of non-ideal behavior. Subsequently, open loop operation has proven to be irrational from any point of view (performance, complexity, power supply requirements)

[17], and the control system is thus an essential part of any PMA system. Recently, a suite of control methods for analog PMAs were investigated [12].

As presented in

[14] MECC has two fundamental variants henceforth referred to as MECC(N) and MECC(M,N). Fig. 2 shows the extended general (N+M)-loop MECC(N,M) topology. Fundamentally, MECC is a recursive structure of N loops formed as an *enhanced cascade* from a single feedback source. This simple extension offers some advantages. MECC(N) is characterized by the following distinct points:

- A *single* feedback source.
- A *single* feedback path $A(s)$ independent upon the number of loops N, providing a minimal system complexity.
- The feedback path has a *low-pass* characteristic, to filter the noise from v_p and compensate the demodulation filter.
- An initializing $B_1(s)$ compensator block with special characteristics.
- A *recursive* structure with a set of preferably *identical* forward path compensator blocks $B_i(s)$.

Thus, the *Enhanced Cascade* refers to these special cascade control characteristics or this dedication of

the cascade to the PMA control problem. Cascade control methods have previously been applied to linear power amplifier systems, in terms of e.g. the well known Nested Differential Feedback Loop method (NDFL's) presented by Cherry [3]. The motivation for developing MECC for PMA system has been similar to Cherry's for linear amps. The characteristic effective loop transfer function is shown in Fig. 3.

A fundamental constraint within MECC(N,M) system design is:

$$M \geq 1 \Rightarrow N \geq 1 \tag{1}$$

MECC(N) provides optimized control in dedicated applications where filter linearity is unproblematic and the load is known. The MECC(N,M) provides optimized control in all general applications. Both topologies have their place.

The MECC(N,M) topology is founded on a MECC(N) design and should be seen as a direct extension of this topology. The MECC(N,M) topology is characterized by:

- A MECC(N) system, that is optimized specifically for the global enhanced cascade.
- A *single* feedback source v_o .
- A *single* feedback path compensator C .
- A D_1 compensator to initialize the cascade.

- A *recursive* structure with a set of preferably *identical* compensator blocks D_i .

The topological resemblance between MECC(N) and MECC(N,M) also leads to similarities in the synthesis of the two cascade structures. However, MECC(N,M) is constituted of two closely connected enhanced cascades, where the global enhanced cascade relies on the compensation from the local cascade. Loop synthesis in the MECC system is addressed in

[14],

[15]. As also shown in

[14],

[15] - a high performance level can be achieved by the MECC(1,1) topology.

3. The novel COM modulator topology

This paper extends previous research and proposes a new modulation techniques optimally suited to the MECC control system. Traditional PWM techniques or PDM techniques provides certain limitations

[15] to the MECC control system. PWM has a range of shortcomings as e.g.:

- Precision carrier implementation is troublesome. Errors on the carrier limit performance.
- Control system design is complicated.
- The high amplitude switching noise source limits control system bandwidth.

Stable and robust control system design is difficult

- [15].

Accordingly, the primary objective in the search for more suitable modulation techniques has been to develop a modulation technique that overcomes some of these fundamental problems.

The result of the extensive search for better methods is the *Controlled Oscillation Modulator (COM)*¹. The basic topology is shown in Fig. 4. The COM system is a combined modulation and control system surrounding a central power conversion stage. As seen in the isolated system in Fig. 4, an input reference voltage v_i is feed to a compensation unit B, also feed by the feedback compensator A to derive and process error information. The compensated signal v_b is feed to a comparator which is referenced to a constant voltage v_{DC} , preferably a DC voltage. The resulting pulse modulated signal is power amplified in a switching power conversion stage supplied by V_s , generation the power pulse signal V_p , this pulse signal driving an inductive load. The A block processes output information from the output voltage V_p and controls the overall transfer function characteristics of the system. The COM system is characterized by at least one pole in the A and B blocks, in combination with

¹ COM is proprietary technology of Bang&Olufsen PowerHouse a/s.

the propagation delay of the modulator and power stage generating a sinusoidal like modulating signal v_b , to be compared with v_{DC} . Under these presumptions, the system realizes a oscillating system at the frequency of positive feedback. The typical characteristic of the COM modulating signal is illustrated in Fig. 5.

3.1 COM system example

Consider the system in fig. 5. Assuming, that a constant gain K is desired over a certain bandwidth, example general A and B block characteristics are:

$$A(s) = \frac{1}{K} \frac{1}{\tau_1 s + 1} \frac{1}{\tau_o s + 1} \qquad B(s) = K_B \frac{\tau_{zB} s + 1}{\tau_{pB} s + 1} \frac{1}{\tau_o s + 1} \qquad (1)$$

In this illustrative example, the A-block having a first order characteristic with a pole $s = -\tau_1$ placed at lower frequencies, generally more than a decade below the desired oscillation frequency. The oscillation conditions are conformably determined by τ_o with the two poles placed at $s = -\tau_o = -\frac{1}{\omega_0}$. The requirements for a

" Controlled Oscillation Modulation " is:

$$|L(j\omega_o)| = |K_p A(j\omega_o) B(j\omega_o)| = 1 \quad \wedge \quad \sphericalangle L(j\omega_o) = 180^\circ \qquad (2)$$

where the desired system oscillation frequency is ω_0 . Hence, in this preferred example, the condition for controlled oscillation is:

$$|K_B K_P| = K \frac{\omega_0 \tau_{p1} \tau_{pB}}{2\tau_{zB}} \quad (3)$$

The COM system will be forced to oscillate at ω_0 due to the non-linear gain characteristic of the comparator and power stage. The resulting COM system is easily integrated in the MECC system. Actually, the COM system is equivalent to a MECC(1,0) system [15].

COM offers superior characteristics compared to widely used carrier PWM and PDM techniques. Some of the general advantages of COM are:

- The COM system is inherently unstable leading to robust operation.
- Very simple implementation. No carrier generator is needed saving components and improving quality (no distortion, noise, jitter etc. from carrier or clock generator).
- The power supply variable V_s is eliminated from the effective loop transfer function. The rejection to perturbations on V_s is infinite as opposed to none in e.g. a PWM system or a limited factor in a feedback PWM system.

- The bandwidth of the control system is approximately equal to the resulting carrier frequency.
- The modulation is clean with a comparison of a sinusoidal signal with zero or a DC voltage.
- Controlling loop order and propagation delay can control the switching frequency variation for improved EMI and efficiency.

4. Evaluating the MECC/COM PMA topology

The MECC/COM PMA topology has been thoroughly evaluated and optimized and three cases will be investigated in the following. The case examples are the ICE250A, ICE500A and ICE1000A products which have been implemented using selected variables for the modulator and control system. Essential parameters for the three case examples are shown below:

Parameter	ICE250A	ICE500A	ICE1000A
Av. output power	250W	500W	1000W
f_b	80kHz	80kHz	40kHz
f_c	400kHz	400kHz	200kHz
N	1	1	1
M	1	1	1
Vp	50V	75V	110V
K	26dB	26dB	26dB

A picture of the three ICEpower modules is shown in Fig. 6. In general, the power stage implementation is

very relaxed and optimized for efficiency. Open loop THD is 1-2% worst case. Since the performance is equivalent for the three power levels, we will focus on ICE500A performance.

Fig. 7 illustrates the frequency response of the system in 2.7Ω to open load. The system response is within $\pm 0.2\text{dB}$ in all loads from 2Ω to an open load situation. This is due to the very low output impedance of the system, which is below $25\text{m}\Omega$ at all frequencies.

Fig. 8 shows THD+N at various frequencies for the 250W case module. 7kHz loading corresponds to the worst case situation with 22kHz and 30kHz bandwidth filtering (AP). For the higher power modules, the performance is equivalent [22].

Fig. 9 shows an FFT analysis of the amplifier output at 5kHz/100mW. The analysis reveals the extreme linearity of 0.0005% or -106dB of the MECC based PMA system at typical output powers - even at higher frequencies. This is quite exceptional for such a high power PMA system and fully comparable with what is achieved by the very best linear power amplifiers. As shown in Fig. 8, a high level of linearity is maintained at all frequencies and output powers.

Thus, THD+N maintains to be below 0.025% to the maximum output levels in the tweeter range.

Fig. 10 illustrates the efficiency characteristics, again for the 250W case example in an 8 ohm load. Notice the high efficiency also at lower output powers.

Detailed specifications for the 250W case example are illustrated on the following page.

Electrical Specifications - 250W case example

SYMBOL	PARAMETER	CONDITIONS	TYP	UNIT
V_p	Power Supply	Operation	50	V
P_o	Output power @ 0.05%THD+N 10Hz < f < 20kHz (22kHz BW measurement)	RL=4Ω. V _p =50V	200	W
		RL=8Ω. V _p =50V	110	
THD+N	THD + N in 4Ω	f = 1kHz, P _o =1W	0.005	%
THD+N	Maximal THD + N in 4Ω (22kHz BW measurement)	10Hz < f < 20kHz 100mW < P _o < 200W	0.03	%
I_{v_p}	Quiescent current	V _p =50V	30	mA
f_o	Offset switching frequency	Offset carrier at idle	380	kHz
n	Power stage Efficiency	R _L =8, P _o =100W	93	%
PSRR	Power Supply Rejection		70	dB
V_{No}	Output referenced idle noise	A-weighted 10Hz < f < 20kHz	65	μV
V_{OFF}	Output referenced offset (DC calibration active)	Terminated input	5	±mV
A_v	Nominal Voltage Gain		27.0	dB
F	Frequency response	20Hz-20kHz, All loads	±0.2	dB
f_u	Upper bandwidth limit (-3dB)	R _L =8	80	kHz
f_l	Lower bandwidth limit (-3dB)	R _L =8	4	Hz
Z_o	Abs. output impedance	f = 1kHz	5	mΩ
D	Dynamic range	A-weighted	115	dB
IMD1	Intermodulation (CCIF)	f=19kHz, 20kHz, P _o =10W	0.001	%
IMD2	Intermodulation (SMPTE)	f=60Hz, 7kHz (1:4), P _o =10W	0.001	%
TIM	Transient intermodulation (TIM)	f1=3.15kHz square, f2=15kHz, P _o =10W	0.001	%

Detail specifications for the MECC/COM based full bandwidth
PMA system.

5. Conclusions

The paper has presented a novel PMA topology realizing state-of-the-art performance. A novel modulator topology was presented - *Controlled Oscillation Modulation (COM)* - which integrates well with the previously proposed MECC control topology. The COM modulator proves to have many advantageous characteristics over conventional PWM or PDM modulator topologies:

- No carrier generator is needed saving components.
- Inherently unstable - hence very robust since damaging instability cannot occur.
- The power supply variable V_s is eliminated from the effective transfer function - \rightarrow PSRR is infinite.
- The bandwidth of the control system is approximately equal to the resulting carrier frequency.
- The modulation is clean with a comparison of a sinusoidal signal with zero or a DC voltage. This improves the precision of the system.
- A controllable variable switching frequency (by controlling loop order and propagation delay) improves efficiency and can be used to lower EMI.

These theoretical advantages have been extensively proved in practice by the implementation of three case examples; 250W, 500W and 1000W. To conclude, the PMA performance level and sound quality is now

fully comparable with high end linear class A/B technology and on many parameters superior to linear class A/B amplifiers with the presented topology.

6. Patent protection

The MECC and COM methods are protected by several patents and patent applications and are the proprietary rights of Bang & Olufsen PowerHouse a/s.

7. Acknowledgement

The authors are very grateful to professor Michael.A.E.Andersen at IAE/DTU. Our fruitful research partnership in efficient power conversion for audio reproduction is the very foundation for the results presented in this paper.

8. References

- [1] Duncan, Ben
" High Performance Power Amplifiers "
Newness. Butterworth, Heineman. 1997.
- [2] Attwood, B.E.
" Very high Fidelity Quartz Controlled PWM (Class D) Stereo Amplifiers for Consumer and Professional Use"
59th Convention of the AES. March 1978. Hamburg. Paper 1331.
- [3] Cherry, E.M.
" Nested Differentiating Feedback Loops in Simple Audio Power Amplifiers "
JAES. Vol. 30, No.5, May 1982. pp. 295-305.
- [4] Vanderkooy, John
"New concepts in Pulse Width Modulation "
97th Convention of the AES, November 1994. San Francisco.
Preprint 3886.
- [5] Klugbauer, Josef
"A Sigma-Delta Power Amplifier for Digital Input Signals"
102nd AES Convention. Munich, March 1997. Preprint 4448.
- [6] Anderskov Niels, Nielsen, Karsten. Andersen, Michael.
"High Fidelity Pulse Width Modulation Amplifiers based on Novel Double Loop Feedback Techniques"
100th AES Convention. Copenhagen, May 1996. Preprint 4258.
- [7] Nielsen, Karsten
" Parallel Phase Shifted Carrier Pulse Width Modulation (PSCPWM) -

A novel approach to switching power amplifier design "
102nd AES Convention. Munich, March 1997.

Paper 4447

[8] Nielsen, Karsten

" A Review and Comparison of Pulse Width Modulation methods
for

analog and digital input switching power amplifier systems "

102nd AES Convention. Munich, March 1997.

Paper 4446.

[9] Nielsen, Karsten

"High Fidelity PWM based Amplifier Concept for active speaker
systems with a very Low Energy Consumption"

Journal of the Audio Engineering Society. July/August 1997.

pp. 554-570.

[10] Nielsen, Karsten

" Pulse Edge Delay Error Correction (PEDEC) - A Novel Power
Stage Error Correction Principle for Power Digital-Analog
Conversion"

103rd AES Convention. New York, September 1997.

Paper 4602.

[11] McLaughlin, R. David, Stanley, Gerald R. and Wordinger,
James.

"Audio Amplifier Efficiency and Balanced Current Design - A
New

Paradigm"

103th AES Convention. New York, USA. September 1997.

[12] Nielsen, Karsten, Taul, Thomas, Andersen, Michael

" A comparison of Linear and Non-Linear Control Methods for
Power

Stage Error Correction in Switching Power Amplifiers "
104th AES Convention. Amsterdam, Holland.

[13] Risbo, Lars, Mørch, Thomas
"Performance of an all digital power amplification system"
104th AES Convention. Amsterdam, Holland.

[14] Nielsen, Karsten
" MECC - A novel control method for high end switching audio
power amplification "
105th AES Convention. San Francisco, USA. Preprint 4839.

[15] Nielsen, Karsten
" Audio Power Amplifier Techniques with Energy Efficient Power
Conversion ".
Ph.D. Thesis.
Department of Applied Electronics, DTU, Denmark. May 1998.

[16] Nielsen, Karsten
" PEDEC - A Novel Pulse Referenced Control Method for High
Quality Digital PWM Switching Power Amplification "
IEEE Power Electronics Specialist Conference (PESC).
Japan, May 1998. Conf. Proc. pp. 200-208.

[17] Nielsen, Karsten
" Linearity and Efficiency Performance of Switching Power
Amplifier
Output Stages - A fundamental analysis "
105th AES Convention. San Francisco. September, 1998.

[18] Nielsen, Karsten
"Digital Pulse Modulation Amplifier systems based on PEDEC
control"
106th AES Convention. Munich, Germany. March, 1999. 25 pp.

Paper 4942

[19] Nielsen, Karsten

"Parallellised Phase Shifted Carrier Pulse Width Modulation
(PSCPWM)

schemes - A fundamental analysis "

106th AES Convention. Munich, Germany. March, 1999. 25 pp.

Paper 4917

[20] Johansen, Morten, Nielsen, Karsten

" A review and comparison of digital PWM methods for digital
pulse

modulation amplifier systems "

107th AES Convention. Munich, Germany. March, 1999.

Paper 5039

[21] Christensen, Frank, Frederiksen, Thomas, Andersen,
Michael, Nielsen,
Karsten

" Practical Implementation and Error Analysis of PSCPWM based
switching power amplifier systems "

107th AES Convention. Munich, Germany. March, 1999.

Paper 5040

[22] Web-site: www.BangOlufsen-PowerHouse.com

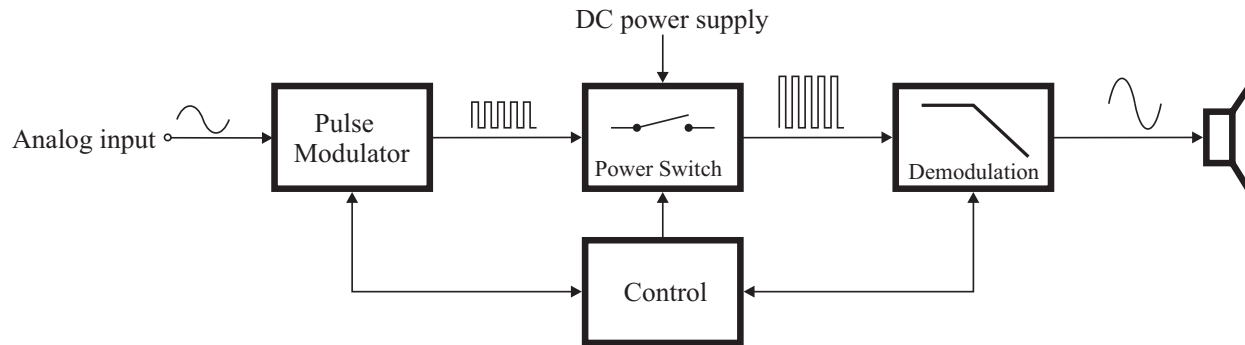

Fig. 1 General analog Pulse Modulation Amplifier topology.

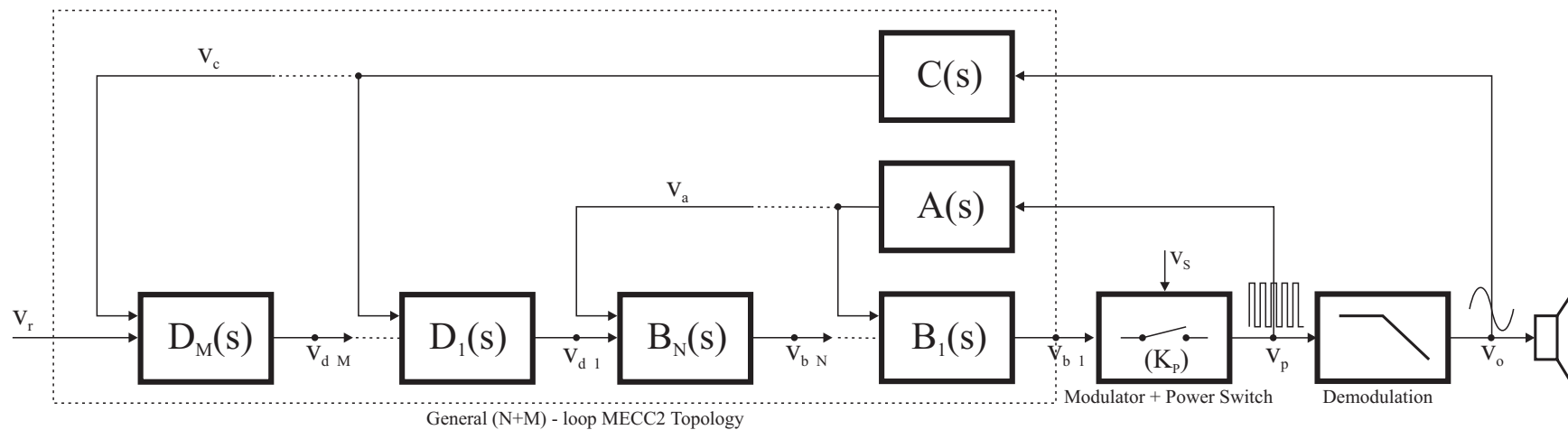

Fig. 2 General (N+M) - loop MECC(N,M) topology

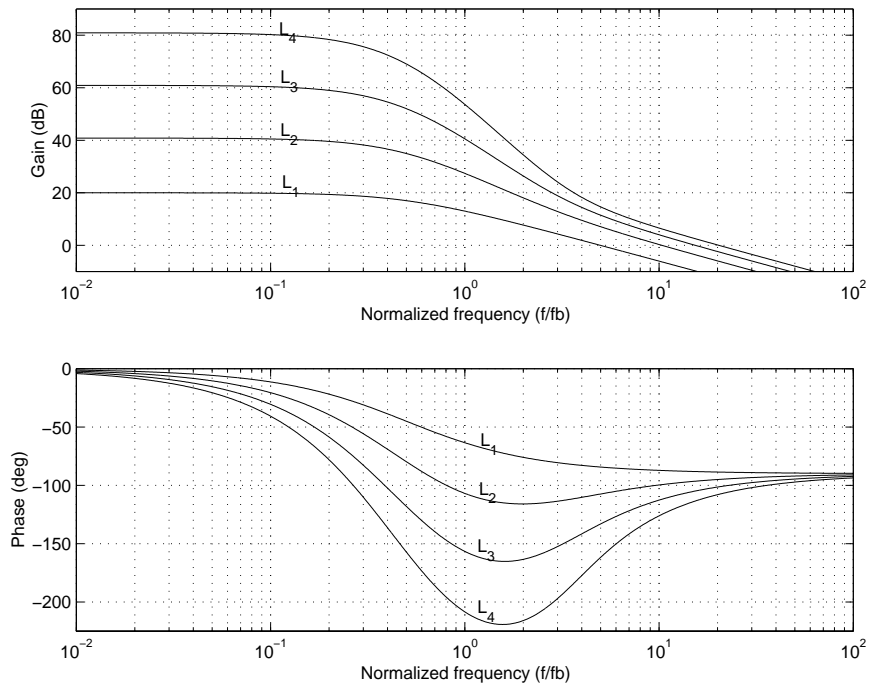

Fig. 3 MECC(N) parametric analysis of effective loop transfer function L_N . ($N = 1, 2, 3, 4$).

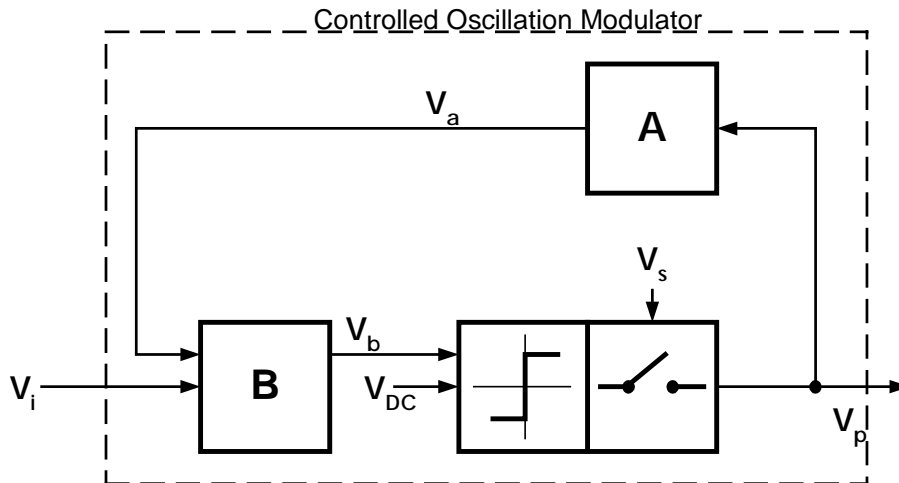

Fig. 4 Basic idea of COM system

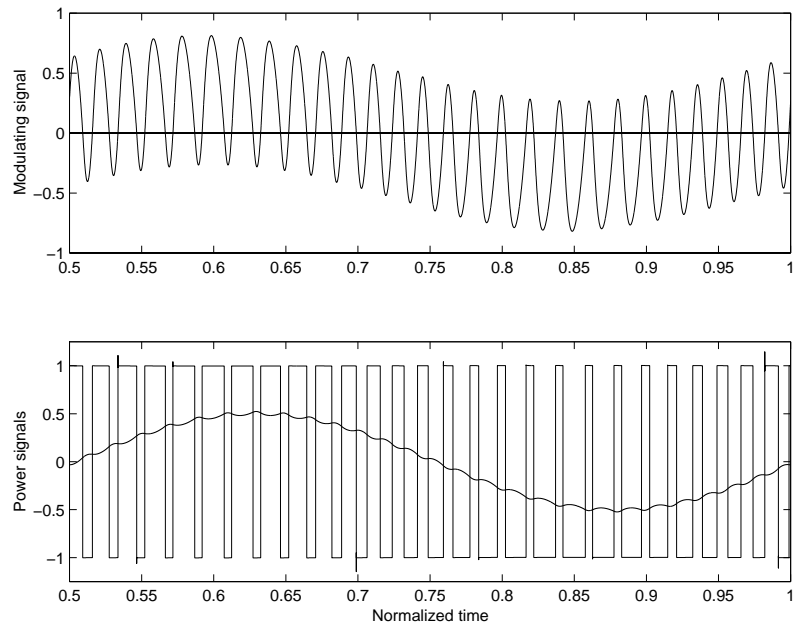

Fig. 5 Modulating signal



Fig. 6 Modules implemented with the MECC/COM topology. Physical size is only 80x80x25mm (250W), 90x90x25mm (500W) and 100x100x25mm (1000W), respectively.

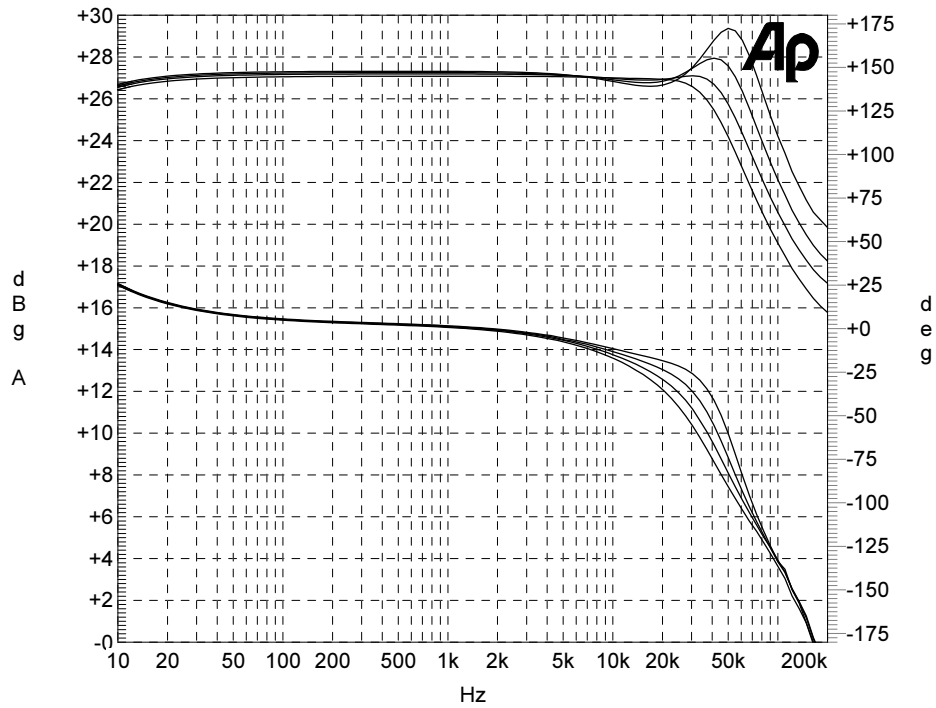

Fig. 7 Frequency Response in 2.7Ω , 4Ω , 8Ω and open load. Top - amp. Bot - Phase.

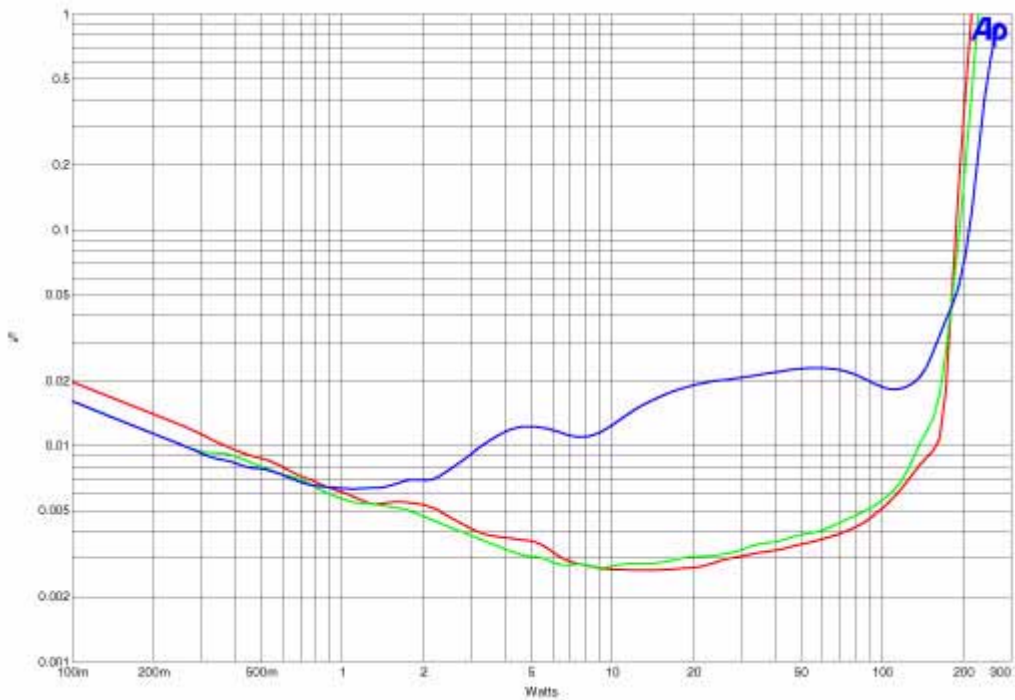

Fig. 8 THD+N at 100Hz, 1KHz and 7kHz in a 4 ohm load (22kHz bandwidth). 250W case.

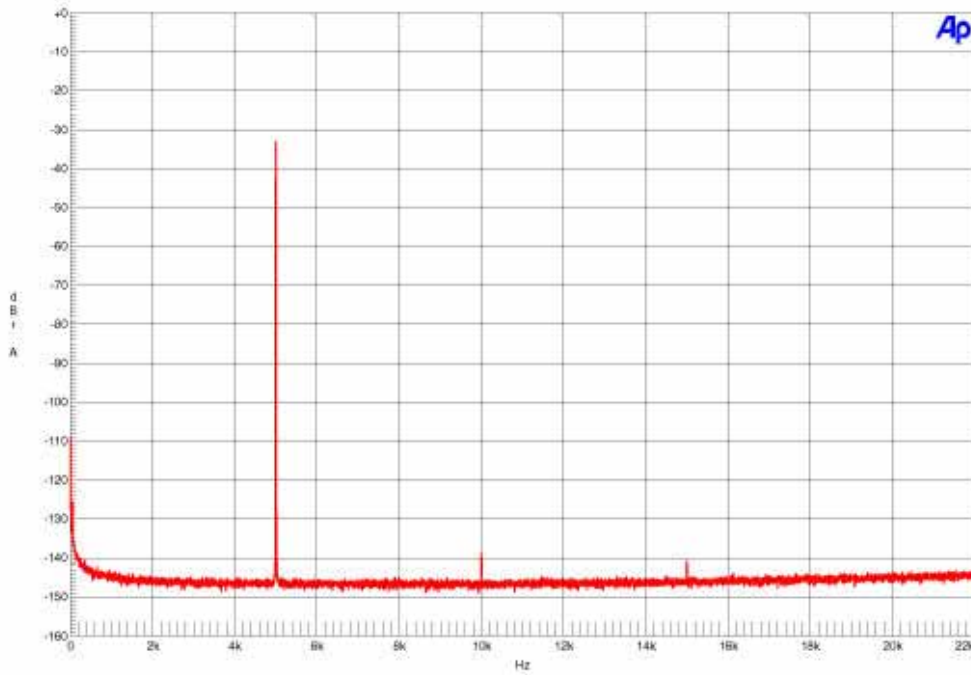

Fig. 9 16K/16x av. FFT at 5KHz/100mW. 250W case. THD = -106dB

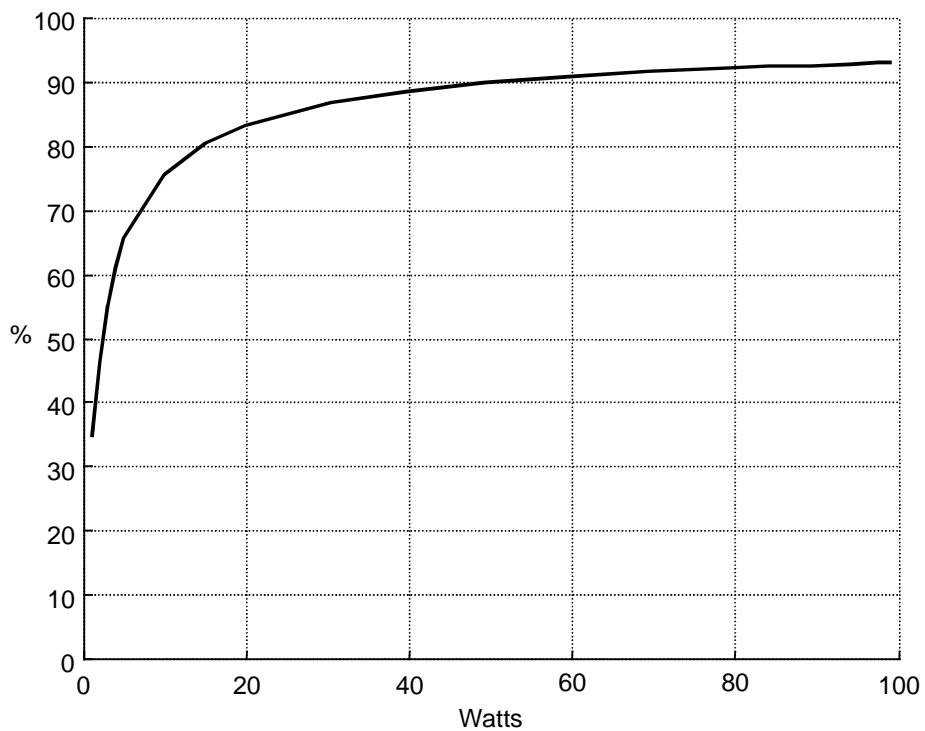

Fig. 10 Efficiency vs. output power. 250W case (8 ohm load).